

MODEL 81000
ULTRASONIC ANEMOMETER



OCTOBER 2001

MANUAL PN 81000-90

R. M. YOUNG COMPANY

2801 AERO-PARK DRIVE, TRAVERSE CITY, MICHIGAN 49686, U. S. A.
TEL: (231) 946-3980 FAX: (231) 946-4772



MODEL 81000 ULTRASONIC ANEMOMETER



1.0 SPECIFICATION SUMMARY

WIND SPEED

Range: 0 to 40 m/s (0 to 90 mph)
 Resolution: 0.01 m/s
 Threshold: 0.01 m/s
 Accuracy: $\pm 1\%$ rms ± 0.05 m/s (0 to 30 m/s)
 $\pm 3\%$ rms (30 to 40 m/s)

WIND DIRECTION

Azimuth Range: 0.0 to 359.9 degrees
 Elevation Range: ± 60.0 degrees
 Resolution: 0.1 degree
 Accuracy: $\pm 2^\circ$ (1 to 30 m/s)
 $\pm 5^\circ$ (30 to 40 m/s)

SPEED OF SOUND

Range: 300 to 360 m/s
 Resolution: 0.01 m/s
 Accuracy: $\pm 0.1\%$ rms ± 0.05 m/s (0 to 30 m/s wind)

SONIC TEMPERATURE

Range: -50 to +50 °C
 Resolution: 0.01 °C
 Accuracy: ± 2 °C (0 to 30 m/s wind)

GENERAL

Air sample column: 10 cm high X 10 cm diameter
 Air sample path: 15 cm
 Internal sample rate: 160 Hz
 Output sample rate: 4 to 32 Hz (selectable)
 Output formats: Serial data (selectable)
 4 voltage output channels 0 to 4000 mV
 RS-232 full duplex
 RS-485 half duplex (can be bussed)
 Baud Rates: 1200 to 38400
 Power Supply: 12 to 30 VDC, 4 watts
 Dimensions: Overall height 56 cm
 Support arm radius 17 cm
 Mounting 34 mm (1.34 in) diameter
 (standard 1 inch pipe)
 Weight: Sensor weight 1.7 kg (3.8 lb)

2.0 INTRODUCTION

The Young Model 81000 measures three dimensional wind velocity based on the transit time of ultrasonic acoustic signals. From speed of sound, sonic temperature is derived. Speed of sound and sonic temperature are corrected for crosswind effects.

Measurement data are available as voltage output signals or serial output using RS-232 or RS-485 connections. Both voltage and serial output may be configured for various of output formats.

Operating parameters may be edited using ordinary terminal software on a PC. Simple menus make it easy. All parameters are stored in nonvolatile memory.

Superior environmental resistance is achieved by using UV stabilized thermoplastic, stainless steel, and anodized aluminum components. Electrical connections are made via an easily accessible junction box. The unit mounts on standard 1 inch pipe, outside diameter 34mm (1.34").

3.0 INITIAL CHECKOUT

Carefully unpack the unit and inspect for physical damage. Any damage should be reported to the shipper. The 81000 arrives fully calibrated and ready to use. A simple four-step operational check may be performed as follows:

1. Remove junction box cover. Connect power and signal wires to terminals as indicated in wiring diagram for "RS-232 output." Connect serial cable to computer COM port.
2. Start an ordinary serial communications program (like HyperTerm) with baud rate at 38400 and flow control set to NONE.
3. Apply power to the 81000 sensor. There will be a brief delay for initialization then the unit will begin to output data at four times per second using the following format: speed (m/s) azimuth (deg) elevation (deg) speed-of-sound (m/s) sonic-temperature (°C). Verify that all values are present on the display. Typical output is shown below:

0.00	0.0	0.0	346.70	25.14
0.00	0.0	0.0	346.68	25.11
0.00	0.0	0.0	346.76	25.25
0.00	0.0	0.0	346.80	25.30
0.00	0.0	0.0	346.76	25.25
0.00	0.0	0.0	346.80	25.30
0.00	0.0	0.0	346.80	25.30
0.00	0.0	0.0	346.82	25.35

A threshold level of 0.2 m/s is preset from the factory. Wind below the threshold, such as in still air, is output as 0.00 m/s. Azimuth may be any value from 0.0 to 359.9 degrees. When wind speed is below threshold level, azimuth output is maintained at the last value read before the wind went below threshold. Elevation remains zero until threshold is exceeded. Speed of sound ranges from 300 m/s to 360 m/s depending on temperature. At 20°C the value is about 344 m/s. Sonic temperature may be compared to a standard Celsius thermometer and should agree within $\pm 2^\circ\text{C}$. If values appear questionable or any value is not displayed, remove power and check all wiring connections. If the problem cannot be corrected contact your YOUNG representative.

4. Verify sensor response by gently blowing through the measuring section. Wind from the north side (marked "N"), should produce a positive SPEED response and an AZIMUTH display corresponding to North (i.e.: values around 359.9 or 0.0). Wind from the opposite direction should produce values indicating south, (around 180.0) and so forth. Downward wind produces negative ELEVATION values, upward wind produces positive values.

After proper operation is confirmed, the sensor may be installed. Complex data collection or serial communication schemes should be tested and verified before final installation. It is easier to confirm wiring connections and communication protocol on a test bench than a tower. Factory settings may be changed by following the instructions in the next section.

4.0 COMMAND MENU

Sending the ESC character (ASCII 27) three times in quick succession takes the unit out of OPERATE mode and causes the COMMAND MENU to appear.

```

COMMANDS (VERSION 3.0.0.0)
-----
R)  REPORT
S)  SETUP
X)  EXIT TO OPERATE MODE

```

Access each menu item by sending the character associated with the menu item of interest. Characters may be upper or lower case. Send "X" to return to OPERATE mode. The following paragraphs explain the function of each menu item and associated sub-menu. The version number may differ from that shown above.

5.0 REPORT

REPORT summarizes current parameter settings. Some parameters are for factory diagnostics only and cannot be accessed or altered by the user. Typical values appear below.

```

PATH LENGTH (cm)  CH  DELAY (uS)  CL
-----
A  15.341         1  19.650  516
B  15.245         2  23.875  570
C  15.146         3  26.675  511
                   6  26.500  466

```

```

OUTPUT FORMAT: CUSTOM
34567 [ 3D-SPEED AZIMUTH ELEVATION SOS Ts ]
WIND SPEED UNITS: m/s
OUTPUT RATE: 4 Hz
SAMPLES FOR AVERAGE: 0
MODE: AUTO
WAKE CORRECTION: YES
ERROR HANDLING: OMIT INVALID DATA
VOLTAGE OUTPUT FORMAT: SPEED, AZIMUTH, ELEVATION, TEMP
VOLTAGE OUTPUT SCALE: 0 TO 40 m/s = 0-4000 mV
                      0 TO 540 DEG AZIMUTH = 0-4000 mV
                      -60 TO +60 DEG ELEVATION = 0-4000 mV
                      220 K TO 320 K = 0-4000 mV
CORRELATION TOLERANCE: 125
COMPARE SHIFT: 0
MANUAL GAIN: 0
AGC LEVEL: 1125
AGC INCREMENT: 5
HI SPEED ADC SAMPLES: 10
THRESHOLD: 20 cm/s
TRANSDUCER FREQ REF: 8333
TRANSDUCER FREQ: 245.7 KHz
ACCESS LEVEL: NORMAL

```

6.0 SETUP

SETUP allows editing operating parameters to suit the needs of a particular application. The SETUP menu and detailed explanation of each menu item follows:

```

SET PARAMETERS
-----
A)  AVERAGING
B)  BAUD
E)  ERROR HANDLING
M)  MODE
N)  SCALING
O)  OUTPUT RATE
P)  POLL CHARACTER (ADDR)
S)  SERIAL OUTPUT FORMAT
T)  THRESHOLD
U)  UNITS
V)  VOLTAGE OUTPUT FORMAT
W)  WAKE CORRECTION
X)  EXIT TO MAIN MENU

```

6.1 AVERAGING

AVERAGING sets the number of output samples used to calculate block averages of all measurements including voltage inputs. Averaged results appear in both serial output and voltage output formats.

For no averaging, set NUMBER OF SAMPLES TO AVERAGE to 0. Otherwise, set it to the number of output samples to be used for calculating the block average. The rate at which block averages are output is determined by OUTPUT RATE and NUMBER OF SAMPLES TO AVERAGE parameters. For example, if OUTPUT RATE is 4 Hz and NUMBER OF SAMPLES TO AVERAGE is 8, the unit will produce a block average output once every 2 seconds (0.5 Hz).

4 samples x 1 avg result = 1 avg result
second 8 samples 2 seconds

```

NUMBER OF SAMPLES TO AVERAGE: 0
ENTER NEW VALUE (0 - 320):

```

6.2 BAUD RATE

BAUD sets the baud rate for serial communication. Faster baud rates may be required if the output string is long and the output rate is fast (see OUTPUT RATE).

```

BAUD: 38400
-----
A)  1200
B)  2400
C)  4800
D)  9600
E)  19200
F)  38400
X)  EXIT TO MAIN MENU

```

6.3 ERROR HANDLING

ERROR HANDLING determines the manner in which invalid measurements are handled. Invalid measurements can occur when the acoustic path of the sonic signal is blocked or internal circuits fail. Acoustic blockage may be caused by rain drops, ice, snow, or other debris. When set to INCLUDE INVALID DATA, an output always occurs. If CUSTOM serial output is used, an ERROR CODE may be included in the output to indicate the error condition. When set to OMIT INVALID DATA, invalid measurements are not output. See VOLTAGE OUTPUT for details regarding this setting when that output is used.

```

ERROR HANDLING: 2
-----
1)  INCLUDE INVALID DATA
2)  OMIT INVALID DATA
X)  EXIT

```

6.4 MODE

MODE sets the method by which internal samples are processed to produce output samples. MODE may be set to MEAN, MEDIAN, or AUTO. MEAN averages internal samples to produce an output sample and is recommended for low wind velocities (<5 m/s). MEDIAN finds the median of internal samples to produce an output sample and is recommended for higher velocities (>5 m/s). AUTO switches between MEAN and MEDIAN at 5 m/s to offer optimal performance over an extended range.

Do not confuse MODE with AVERAGING described above. Also, do not confuse internal samples with output samples (See OUTPUT RATE).

```

MODE 3
-----
1)  MEAN
2)  MEDIAN
3)  AUTO
X)  EXIT TO MAIN MENU

```

6.5 SCALING MULTIPLIER

SCALING MULT sets overall scaling for UVW, 2D, and 3D wind speed outputs. Azimuth and elevation angle are not effected. The default value of 10000 represents a scaling multiplier of 1.0000. Normally, this value should not be changed since each instrument is calibrated in the YOUNG factory wind tunnel. However, users who wish to alter the scaling based on independent calibration assesment may use this parameter to do so.

```
SCALING MULT : 10000
ENTER NEW VALUE:
```

6.6 OUTPUT RATE

OUTPUT RATE sets the rate at which output samples are available.

Fast output rates and long serial output strings may require higher baud rates in order to keep up with the outgoing data stream. If AVERAGING is used, average results are available only after enough output samples have been collected. See AVERAGING for details.

```
OUTPUT RATE 4Hz
-----
A) 4 HZ
B) 5 HZ
C) 8 HZ
D) 10 HZ
E) 16 HZ
F) 20 HZ
G) 32 HZ
X) EXIT TO MAIN MENU
```

When using the RS-485 communication with higher output rates and long output strings, the half-duplex scheme will spend more of its time sending data with a progressively smaller window of time in which to receive commands. In fact, if the string is long enough and the output rate high enough, the 81000 will not be able to respond to any commands. RS-485 is best used in POLLED MODE or at modest output rates. In contrast, the full-duplex nature of the RS-232 scheme is immune to the limitations described above. Commands can be received while data is being sent.

6.7 POLL CHARACTER

POLL CHARACTER (ADDR) is used to set the address character polled operation (POLL CUSTOM output format). Any printable ASCII character may be used to assign an address that uniquely identifies the instrument. When bussed on an RS-485 network with other 81000 instruments, each one should have a different address character.

```
POLL CHARACTER (ADDR) : A
ENTER NEW CHARACTER:
```

To poll the 81000, send MA! where A is the POLL CHARACTER. The 81000 will respond with the POLL CHARACTER and a space followed by the custom serial output string.

6.8 SERIAL OUTPUT FORMAT

SERIAL OUTPUT FORMAT sets the output string for serial output. Preset and custom formats are available.

```
SERIAL OUTPUT FORMAT 1
-----
1) CUSTOM
2) RMYT
3) NMEA
4) POLL CUSTOM
X) EXIT TO MAIN MENU
```

6.8.1 CUSTOM

CUSTOM format allows the user to construct an ASCII-printable serial output string. Long strings may require higher BAUD rates or lower OUTPUT RATES. (See BAUD and OUTPUT RATE.) Also, see UNITS.

When CUSTOM is selected the following message and sub-menu appear:

```
CURRENT SERIAL OUTPUT FORMAT:
34567 [ 3D-SPEED AZIMUTH ELEVATION SOS Ts ]
CONSTRUCT AN OUTPUT FORMAT BY SELECTING FROM THE LIST BELOW.
ELEMENTS MAY BE IN ANY ORDER. REFER TO MANUAL FOR DETAILS.
-----
1) UVW
2) 2D SPEED
3) 3D SPEED
4) AZIMUTH
5) ELEVATION
6) SOS
7) Ts
8) ERR CODE

ENTER CUSTOM STRING (8 CHARACTERS MAX) : 16
```

UVW is the orthogonal u, v, and w wind velocities. All three values are output. Typically the 81000 is oriented with u-axis aligned east-west and v-axis aligned north-south. In this orientation, +u values = wind from the east; +v values = wind from the north. Wind from below (updraft) = +w. Refer to ORIENTATION KEY drawing for illustration.

2D SPEED is wind magnitude in the u-v plane.

3D SPEED is wind magnitude in three dimensional space.

AZIMUTH is the 0.0-359.9° wind direction angle in the u-v plane. With the 81000 junction box facing south, 0.0° = north, 90.0° = east, 180.0° = south, and 270.0° = west. Refer to ORIENTATION KEY drawing for illustration.

ELEVATION is the ±90.0° wind elevation angle relative to the u-v plane. Values are positive when wind is from below (updraft) and negative when from above (downdraft). Effective elevation angle measurements are limited to ±60.0°. Refer to ORIENTATION KEY drawing for illustration.

SOS is the speed of sound.

Ts is the sonic temperature derived from SOS.

ERROR CODE indicates the validity of the measurement. Any non-zero value indicates an invalid measurement. ERROR HANDLING must be set to use this field.

6.8.2 RMYT

RMYT sends wind speed and direction in a format suitable for use with the YOUNG Model 06201 Wind Tracker display unit. RS-485 outputs must be used. **When RMYT is selected, the baud rate is automatically set to 9600 and threshold set to 10 cm/sec.**

6.8.3 NMEA

NMEA sends wind speed and direction in NMEA marine format to Young Model 06206 Marine Wind Tracker display or other input device. The sentence is \$WIMWV,aaa,R,ss.s,N,A where aaa = wind direction angle in degrees and ss.s = wind speed in knots. **When NMEA is selected, the baud rate is automatically changed to 4800 and threshold set to 10 cm/sec.**

6.8.4 POLL CUSTOM

POLL CUSTOM format allows the 81000 to be polled for an output. See CUSTOM for details on constructing the output string. Poll by sending MA! where A is the POLL CHARACTER ADDRESS. **Allow at least 5 milliseconds between each poll command character.** The 81000 responds with the POLL CHARACTER followed by the custom serial output string. Up to 32 sonic anemometers may be networked using the RS-485 connection. By assigning a unique address to each device, multiple units may run on the same network and respond individually only when polled.

6.9 THRESHOLD

THRESHOLD sets the wind speed threshold in cm/sec. With UVW output format, the absolute value of wind magnitudes below threshold are reported as zero. With SPEED AZIMUTH ELEVATION output format, wind speeds below threshold are reported as zero, azimuth output is maintained at the last value before the wind went below threshold, and elevation remains zero until threshold is exceeded.

```
THRESHOLD (cm/s) :20
ENTER NEW THRESHOLD (cm/s, 0-500) :
```

6.10 UNITS

UNITS sets wind speed units for CUSTOM serial output. Resolution associated temperature units are as follows:

cm/s	1 cm/s	0.01 K
m/s	0.01 m/s	0.01 °C
mph	0.1 mph	0.01 °F
km/h	0.1 km/h	0.01 °C
knots	0.1 kn	0.01 °F

```
UNITS 2
-----
1) cm/s
2) m/s
3) mph
4) km/h
5) knots
X) EXIT TO MAIN MENU
```

6.11 VOLTAGE OUTPUTFORMAT

VOLTAGE OUTPUT FORMAT selects one of two formats for scaled voltage output on outputs V1, V2, V3, and V4. Format 1 selects U V W, format 2 selects SPEED AZIMUTH ELEVATION. Output V4 is SONIC TEMPERATURE. Wind speed scaling may be set by the user. Azimuth, elevation, and sonic temperature scaling is fixed. Regardless of format, full scale output is 0-4000 mV for each channel.

```
VOLTAGE OUTPUT FORMAT 2
-----
1) U V W TEMP
2) SPEED AZ ELEV TEMP
X) EXIT
```

After selecting the format, a prompt for scaling appears:

```
VOLTAGE OUTPUT SCALE: 0 TO 40 m/s
ENTER NEW VALUE (10-60) :
```

In UVW format, \pm scaling is always implied. For example, entering a value of 40 means a -40 to +40 m/s span. Note that for UVW format, 0 wind speed is 2000 mV or mid-scale. In the example above, -40 m/s = 0 mV and +40 m/s = 4000 mV.

In SPEEDAZIMUTHELEVATION format, the SPEED scale represents positive wind speed only. The fixed scale for AZIMUTH is 0 to 540° and ELEVATION is -60° to +60°. An elevation value of 0° = 2000 mV.

For either format, the SONIC TEMPERATURE output scale is 220 K to 320 K = 0 to 4000 mV. **When voltage outputs are used, the SERIAL OUTPUT FORMAT must be set to CUSTOM even**

though the serial output is not used.

See the accompanying wiring diagram for voltage output connection details. Note that when ERROR HANDLING is set to INCLUDE INVALID DATA, voltage outputs go to full scale (4000 mV) when invalid data is present.

6.12 WAKE CORRECTIONS

WAKE CORRECTION enables or disables real-time correction algorithms. To compensate for flow distortions in the wake of support struts and other mechanical features, each 81000 is individually calibrated in the YOUNG factory wind tunnel (NIST traceable) to generate a unique correction table which is stored in the unit. Additional compensating algorithms correct for elevation angle distortions and crosswind effects on speed of sound.

```
WAKE CORRECTION: YES
USE WAKE CORRECTION? (Y/N) :
```

7.0 WARRANTY

This product is warranted to be free of defects in materials and construction for a period of 12 months from date of initial purchase. Liability is limited to repair or replacement of defective item. A copy of the warranty policy may be obtained from R. M. Young Company.

8.0 CE COMPLIANCE

This product has been tested and shown to comply with European CE requirements for the EMC Directive. Note that shielded cable must be used.

Declaration of Conformity

Standards to which Conformity is Declared:

EN 55022 Group 1 (CISPR 22 class B)
EN 50082-1:1997 using
EN61000-4-2:1995
EN61000-4-3:1995 with ENV50204: 1995
EN61000-4-4:1995
EN61000-4-6:1995

Manufacturer's Name and Address:

R. M. Young Company
Traverse City, MI, 49686, USA

Importer's Name and Address:

See Shipper or Invoice

Type of Equipment:

Meteorological Instruments

Model Number / Year of Manufacture:

81000/2000

I, the undersigned, hereby declare that the equipment specified conforms to the above Directives and Standards.

Date / Place:

Traverse City, Michigan, USA May 1, 2000

David Poinsett
R & D Manager, R. M. Young Company



MODEL 81000 ULTRASONIC ANEMOMETER – WIRING CONNECTIONS

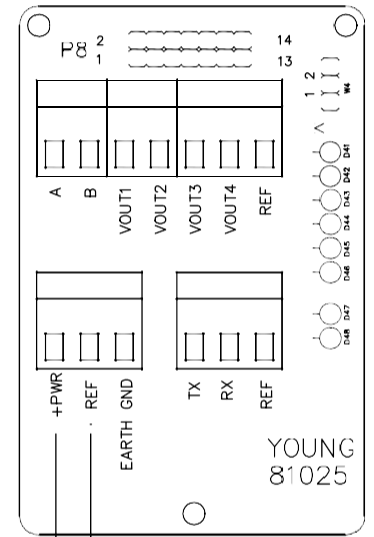
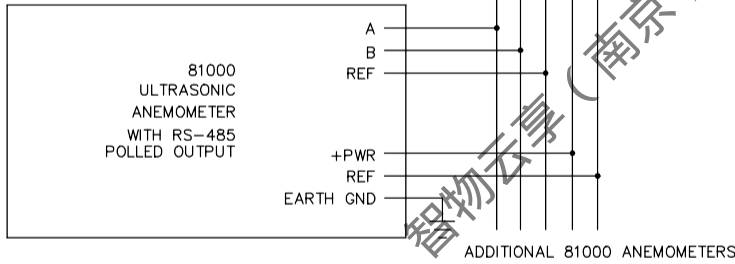
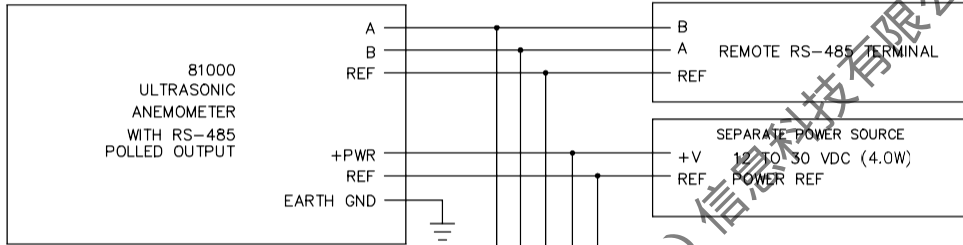
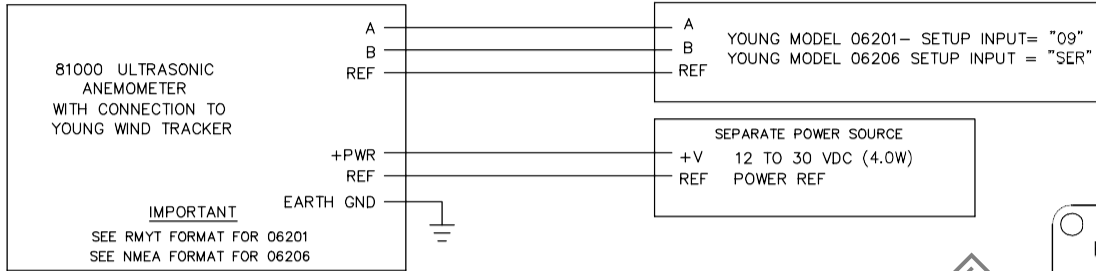
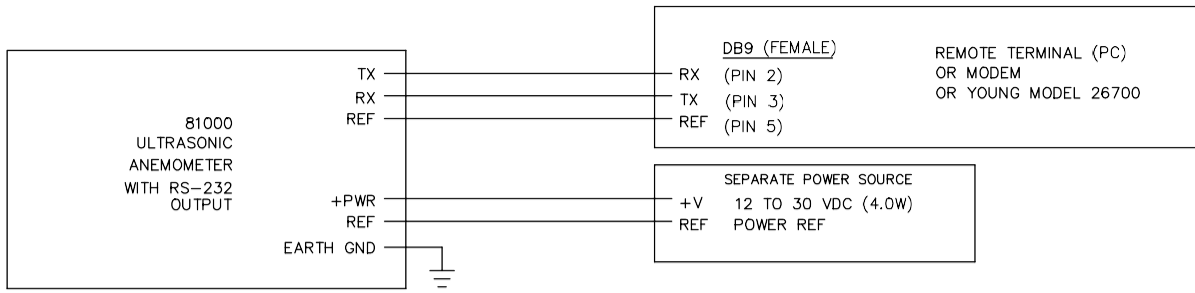

POWER 12 TO 30 VDC (4.0 W)
POWER REFERENCE

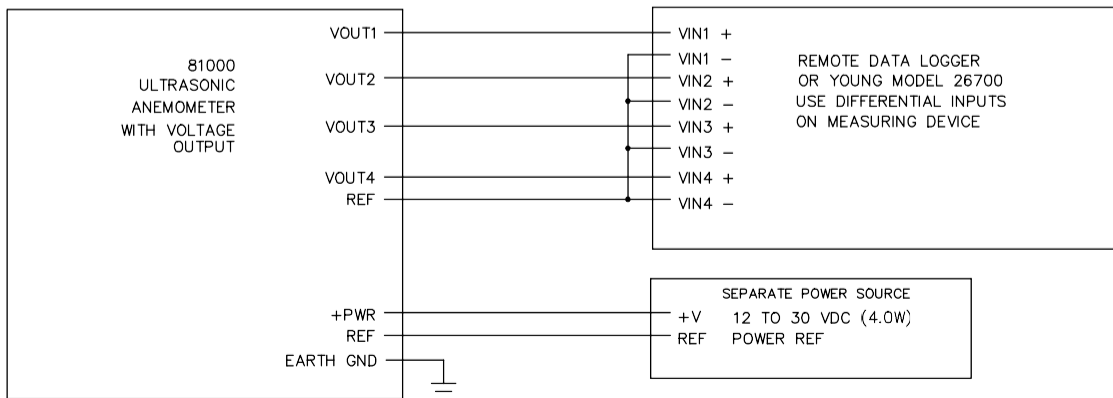

MODEL 81000 ULTRASONIC ANEMOMETER	DWG B	PRD 07-99
TYPICAL WIRING CONNECTIONS	DWN DP	DWG 09-01
	CHK	W81000
R.M. YOUNG CO. TRAVERSE CITY, MI 49686 U.S.A. 231-946-3980		



TYPICAL ORIENTATION:
 JUNCTION BOX FACES SOUTH
 STRUT OPPOSITE JUNCTION BOX POINTS NORTH



TOP VIEW OF 81000
 ULTRASONIC ANEMOMETER

NORTH = 0 DEGREES AZIMUTH
 EAST = 90 DEGREES AZIMUTH
 SOUTH = 180 DEGREES AZIMUTH
 WEST = 270 DEGREES AZIMUTH

智物云 (南京) 信息科技有限公司

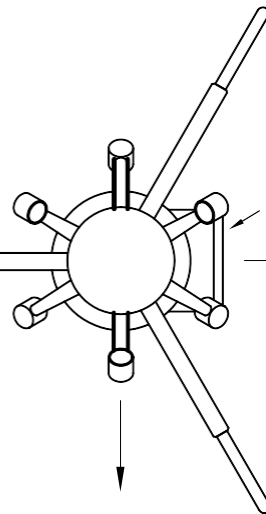

+W WITH WIND
 WIND FROM BELOW



-ELEVATION ANGLE
 WITH WIND FROM ABOVE

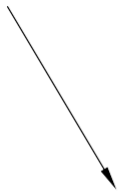

+ELEVATION ANGLE
 WITH WIND FROM BELOW

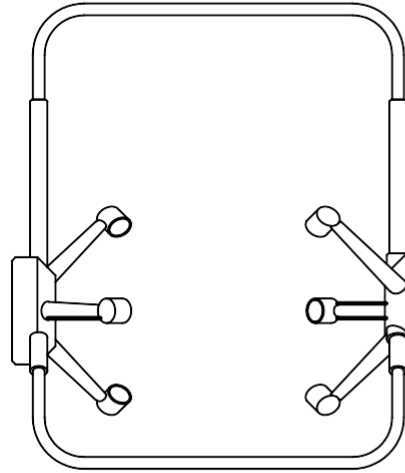

SIDE VIEW OF 81000
 ULTRASONIC ANEMOMETER

JUNCTION
 BOX

ORIENTATION
 RING

MODEL 81000 ULTRASONIC	ANFMOM IFR	DWG A	PRD 09-99
ORIENTATION KEY FOR UVW	DWN DP	DWG 05-00	
AZIMUTH, AND ELEVATION ANGLE	CHN	M81000	
R.M. YOUNG CO. TRAVERSE CITY, MI 49686	U.S.A.	23846-3980	